

MODEL AL Cartridge Filter Housings



The Model AL cartridge filter housing, constructed from durable low-cost cast iron and steel is a quality-built vessel designed to satisfy general-purpose industrial and commercial filtration needs. The Model AL housing features a three piece design with centerpost construction. Long-lasting stainless steel internal components make maintenance quick and easy.

The Model AL is designed to accommodate liquids at a maximum of 150 psi at 250°F. Available in a wide range of sizes, from a 3 cartridge model to an 18 cartridge model, the Model AL can be used in systems with flow rates up to 105 gpm (water).

Applicable Filter Cartridges

Betapure®, Betafine®, Beta-Klean®, Microfluor®, Micro-Klean® III (Series G78 & G80), MPF, Micro-Wynd® II, Petro-Klean®

DESIGN FEATURES

- Materials - Cost effective, durable cast iron and steel with stainless steel internals
- 3-Piece Construction - Housing disassembles for quick and easy cleaning

- Removable Cartridge Posts
- Gauge Port connections
- Convenient Drains and Petcock Vent
- Mounting Pads to securely hold housing

Standard Specifications

Table 1 gives specifications for the Model AL filter housing. In Table 1, note that maximum operating pressure is the rating for the housing only. Actual filter operating temperature depends on capability of the filter cartridge used in the housing.

Model AL Model Specifications		
Operating Data		
Housing Model	3AL	6AL
Maximum Operating Pressure & Temperature	150 psi @ 250°F	
Flow Rate (GPM)	See Table 2	
Connection Sizes	1 1/2" NPTF	2" NPTF
Cartridge Sizes	9 3/4" to 30" cartridges	
Materials of Construction		
Head	Cast Iron	
Cover	Steel	
Shell	Steel	
Centerpost	Steel	
Shell Gasket - Standard	Buna N	
Shell Gasket - Optional	Cork, EPR, Neoprene, Teflon (Order separately)	
Cap Nut	Fiber	
Cartridge Pedestals	304 Stainless Steel	
Cartridge posts	304 Stainless Steel	

TABLE 1 - SPECIFICATIONS

Cartridge Requirements

Table 2 lists the number of filter cartridges required for the Model AL filter housings.

Housing Model	Number of Cartridges/EQSL* Required	Cartridge Length
3AL1	3/3	9 3/4" or 10"
3AL2	3/6	19 1/2" or 20"
3AL3	3/9	29 1/4" or 30"
6AL1	6/6	9 3/4" or 10"
6AL2	6/12	19 1/2" or 20"
6AL3	6/18	29 1/4" or 30"
* EQSL - Equivalent Single Length (9 3/4" or 10")		

TABLE 2 - CARTRIDGE REQUIREMENTS

BENEFITS

- Long Service Life
- Quick and Easy Cartridge Changeout
- Easy to Clean & maintain; Time-Effective and Cost Efficient
- Housing Design Prevents Cartridge Misalignment



Fluid Purification

Flow Rates

Table 2 lists the maximum liquid flow rate (GPM) for the Model AL Filter Housing. Use the data in Table 2 only as a guide in establishing the **maximum** housing flow capability; do not use it for filter sizing. Once the flow rate for a selected cartridge is known, then use Table 3 to check whether the housing's flow rates fall within the recommended guidelines. When sizing a filter, the amount of contaminant to be removed needs to be considered in addition to the flow rate and pressure drop. Low initial pressure drop enhances filter cartridge life.

Filter Housing	Water	80 SSU	150 SSU	300 SSU	600 SSU	1000 SSU
3AL	65	52	43	35	24	18
6AL	105	85	78	70	51	35

TABLE 2 - MAXIMUM FLOW RATES

STANDARD MODEL DIMENSIONS

Table 4 gives dimensions in inches and shipping weight in pounds for the Model AL filter housing. To find a selected dimension of a housing, locate the model in the left column and the selected dimension symbol from Figure 1 (A-C) in the top row. Where the row and column meet is the selected dimension. For critical installation requirements, request a certified drawing.

Filter Model	Dimensions (inches)			Shipping Weight (LBS.)
	A	B	C	
3AL1	19 3/4"	26"	7 5/8"	47
3AL2	30 1/8"	46"		61
3AL3	40	66"		71
6AL1	20 1/2"	27"	9 1/2"	77
6AL2	30 7/8"	47"		94
6AL3	40 3/4"	67"		112

TABLE 4 - DIMENSIONS

REPLACEMENT PARTS

Cuno dealers stock replacement parts for customer convenience. A complete list of replacement parts is enclosed with the product.

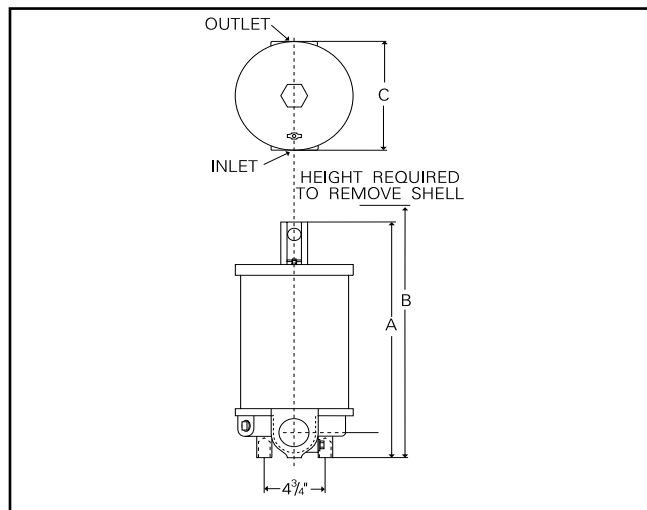

MODEL AL ORDERING GUIDE

Plant Code 01

Product Code 020

Housing Model	Basic Catalog Number
3AL1	44079-01
3AL2	44079-02
3AL3	44079-03
6AL1	44080-01
6AL2	44080-02
6AL3	44080-03

Your Area Distributor Is:

WARRANTY

Seller warrants its equipment against defects in workmanship and material for a period of 12 months from date of shipment from the factory under normal use and service and otherwise when such equipment is used in accordance with instructions furnished by Seller and for purposes disclosed in writing at the time of purchase, if any. Any unauthorized alteration of modification of the equipment by Buyer will void this warranty. Seller's liability under this warranty shall be limited to the replacement or repair, F.O.B., point of manufacture, of any defective equipment or part which, having been returned to the factory, transportation charges prepaid, has been inspected and determined by Seller to be defective. THIS WARRANTY IS IN LIEU OF ANY OTHER WARRANTY, EITHER EXPRESSED OR IMPLIED, AS TO DESCRIPTION, QUALITY, MERCHANTABILITY, FITNESS FOR ANY PARTICULAR PURPOSE OR USE, OR ANY OTHER MATTER. Under no circumstances shall Seller be liable to Buyer or any third party for any loss of profits or other direct or indirect costs, expenses, losses or consequential damages arising out of or as a result of any defects in or failure of its products or any part or parts thereof or arising out of or as a result of parts or components incorporated in Seller's equipment but not supplied by the Seller.

Service Worldwide

Visit us at www.cuno.com



Fluid Purification

CUNO Pacific Pty Ltd
140 Sunnyholt Road
Blacktown, NSW 2148
Australia

CUNO Europe SA
Chemin du Contre Halage
62730 - Les Attaques
France

CUNO Srl
Via Zara, 38
20032 Cormano (Mi)
Italy

CUNO Filtration Asia Pte Ltd
18 Tuas Link 1 (3rd Floor)
Singapore 638597

CUNO Latina Ltda
Rua Amf Do Brasil 251
18120 Mairinque-Sp
Brazil

CUNO GmbH
Wihl-Th-Römheld-Str. 32
55130 Mainz
Germany

CUNO K.K.
Hodogaya Station
Building 6F
1-7 Iwai-cho, Hodogaya-ku
Yokohama 240 Japan

CUNO Ltd
21 Woking Business Park
Albert Drive
Woking, Surrey GU215JY
United Kingdom

Cuno Incorporated

400 Research Parkway
Meriden, CT 06450, U.S.A.

Tele: (800) 243-6894

(203) 237-5541

Fax: (203) 238-8977