

# Filtration Processes Applied in Therapeutic Monoclonal Antibody Production

## Introduction

Monoclonal antibodies were among the first biotechnology produced drugs approved by the FDA and are used to treat specific diseases, as ligands in purification schemes and for use as diagnostic reagents. The primary method of monoclonal antibody production involves using murine systems to produce antibodies to specific (human) antigens. The antigens can be nucleic acid or protein molecules associated with a disease state and the antibodies directed against these antigens are exquisitely specific and identical in structure and function. In order to produce large quantities of monoclonal antibodies, the cells or genes producing the antibodies are fused with cells, typically mammalian, able to be continuously grown in suspension cell culture. The resulting cells are called hybridomas. Many monoclonal antibody producing cell culture systems transport the expressed monoclonal antibodies into the cell culture medium. The purification process begins by separating the monoclonal antibody proteins from the cell mass followed by multiple chromatographic and filtration unit operations.

This CUNO Application Brief presents experience gained from many monoclonal antibody purification systems using CUNO filtration products at the various filtration purification stages.

## The Process

The process to purify monoclonal antibodies from fermentation through final filling is illustrated in Figure 1. CUNO filtration applications described include: media preparation, cell separation, protein concentrate clarification, chromatography column protection and prefiltration prior to final sterilizing filtration.

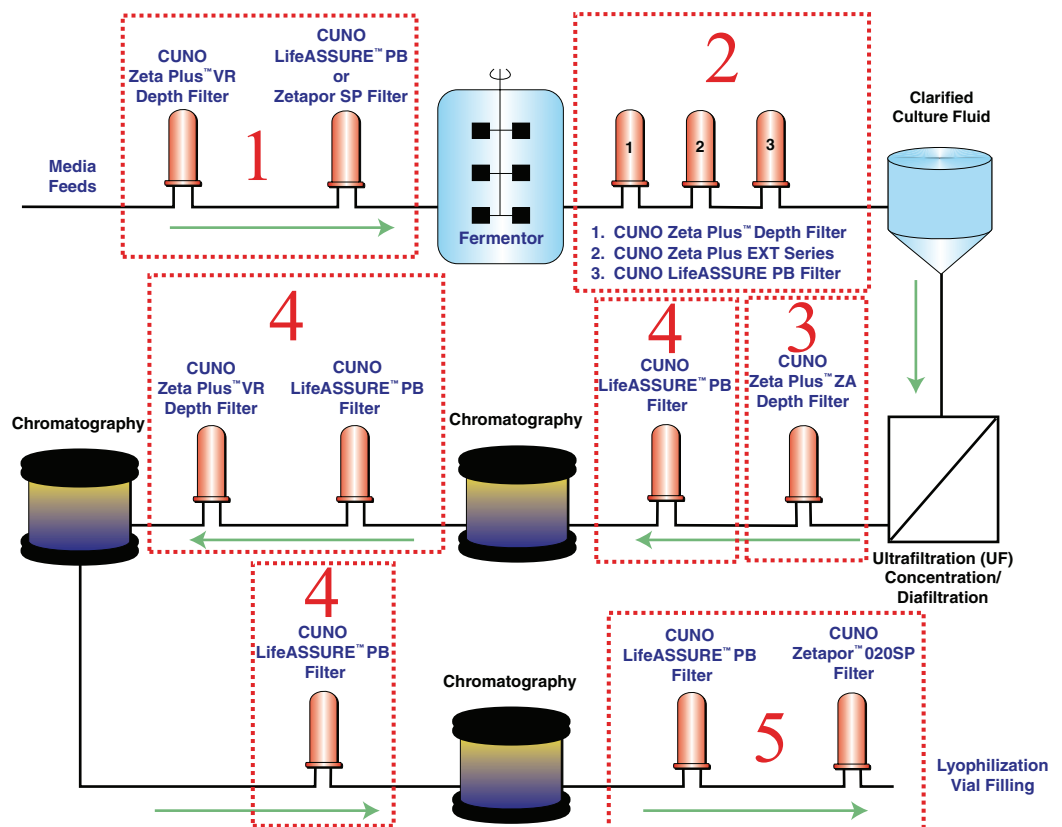

Figure 1 — Typical Manufacturing Process for Ancillary Chemicals

## The Problem

Filtration issues associated with the processing of monoclonal antibody production can be segmented into the following categories. For filtration location in the process, refer to Figure 1.

### *1. Media Filtration*

Filtration is a significant part of the overall purification process of monoclonal antibodies. Large scale monoclonal antibody production processes employ suspension cell culture to grow hybridoma cells which typically secrete monoclonal antibodies into the fermenter fluid. Prior to fermentation however, growth supplements are added to the fermenter vessel to support cell growth. These supplements, called media feeds, can contain contaminants such as virus and bacteria, which can contaminate the fermentation process if not removed. Virus contamination can result from serum containing additives used to supply necessary cell growth factors. Because of the concern with viral contamination, many processes now use serum free media feeds. Even though the possibility of viral contamination may be reduced, filtration is still required to protect against bacterial contamination.

### *2. Cell Separation*

Once media feeds have been added to the fermenter, the process continues until cell growth and antibody production reach optimal levels. At this time the purification process begins with harvest of the fermentation vessel, requiring separation of cell mass from monoclonal antibodies secreted into the culture fluid. Problems associated with the cell separation stage include, yield loss of monoclonal antibodies, cell rupture causing release of proteases, difficulty of filtration based on cell viability and cell number and insufficient removal of cell debris which can compromise downstream purification unit operations.

### *3. Clarification of Protein Concentrate*

Once the cell debris has been sufficiently removed from the culture fluid, purification of monoclonal antibodies continues by concentrating the harvest fluid to a more manageable volume for chromatographic purification. During the concentration step, precipitates can form which must be removed by filtration. If the concentrated solution is not adequately clarified, plugging of downstream chromatography columns can result.

### *4. Chromatography Column Protection*

In addition to removing insoluble debris from protein solutions applied to chromatography columns, many elution buffers and regeneration chemicals applied to columns must also be filtered. One of the more common chemicals used to regenerate and sanitize columns is caustic-sodium hydroxide ranging from 0.25 to 1 molar. Caustic solutions contain particulate material that must be removed; however, many filtration media may not be compatible with caustic solutions.

### *5. Final Fill Prefiltration*

The final step in monoclonal antibody production involves final filling of purified product. Where the final dosage form is liquid, the purified solution must be filtered through a 0.2 micron absolute rated sterilizing filter. In order to obtain maximum performance of the final sterilizing filter, bioburden exposed to the filter and any particulate matter, which can cause shortened life of the final filter, must be removed.

## The CUNO Solution

### *1. Media Filtration*

Numerous reagents including water, growth factors, carbon sources, pH adjusters, etc. are added to the fermentation vessel to support cell growth. These reagents may be added in bulk at the beginning of the fermentation or perfused continuously. A complete discussion of filtration applied in media preparation is available in CUNO Application Brief LITCABLA3. The goal of media filtration is to prevent unwanted contaminants such as bacteria and viruses from entering the fermentation vessel. Three CUNO products, Zeta Plus™ VR Virus Reduction Filters, LifeASSURE™ PB filters and Zetapor™ SP grade filters meet these requirements.

Zeta Plus VR Series filters are recommended where serum containing growth supplements are added to media formulations. Figure 2 shows viral reduction results obtained with Zeta Plus VR Series filters for a panel of viruses spiked into a plasma fractionation process step (Cohn Fr SIII).

**Table 1 — Viral Clearance from Plasma Fraction S III**

| Process Step                 | Cumulative Virus Titer Reduction (Log <sub>10</sub> ) |     |        |     |        |
|------------------------------|---|-----|--------|-----|--------|
|                              | BVD   | EMC | HIV    | PPV | PRV    |
| Solvent Detergent            | > 4.3   | -   | 5.3    | -   | > 7.3  |
| Supernatant III              | 1.4   | 4.3 | 6.1    | 4.7 | 3.8    |
| Zeta Plus VR 03 Depth Filter | 4.8   | 4.5 | 4.7    | 3.7 | 5.4    |
| Total Cumulative Reduction   | 10.5  | 8.8 | > 16.1 | 8.4 | > 16.6 |

The results of viral reduction using Zeta Plus VR Series filters supports their use in reducing viral contaminants possibly associated with serum growth supplements.

In many media formulations, serum supplements are not used due to concerns with viral contamination, however, bacteria retentive filtration is still required. CUNO offers two options for bacteria control. LifeASSURE filters offer high throughput for difficult to filter media additives and bioburden control, with a typical LRV for *B. diminuta* of 7.3. CUNO Zetapor 020SP grade filters offer complete *B. diminuta* retention and have a positive charge for enhanced removal of endotoxins. These attributes are summarized in Table 2.

**Table 2 — LifeASSURE PB and Zetapor SP Grade Filters**

| Filter Type       | Bacteria Retention | Additional Attributes                                 |
|-------------------|--------------------|---|
| LifeASSURE PLA020 | Typical LRV 7.3    | Multizone Flex-N™ medium for high throughput capacity |
| Zetapor 020SP     | Sterilizing grade  | Positive charge for enhanced endotoxin reduction      |

## 2. Cell Separation

One of the most difficult filtration applications is separation of cell mass following fermentation. Zeta Plus depth filtration media is the separation method of choice for this application. For complete details of cell separation, please see CUNO Application Brief LITCABZPS1 and “Clarification of Animal Cell Culture Process Fluids Using Depth Microfiltration”, Singhvi et al, BioPharm 9, Vol 4, April 1996. The goal of the cell separation stage is to remove cell mass, allowing the monoclonal antibody protein to pass. The final filtrate resulting from depth filtration must be able to pass through a 0.2 micron rated filter prior to further downstream purification. The factors most affecting this filtration step are cell density, cell viability and flux of filtration.

Cell density for monoclonal antibody fermentation can range from 10<sup>6</sup> cells/ml to 10<sup>7</sup> cells/ml and the higher cell density results in reduced throughput per square foot of filtration media employed. The effects of cell viability and flux are shown in Figures 2 and 3.

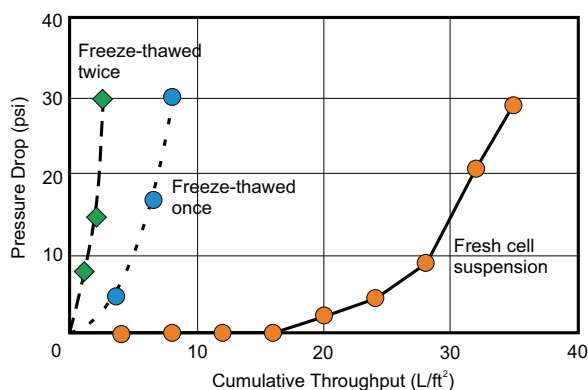

**Figure 2 — Filter Throughput vs. Cell Condition**

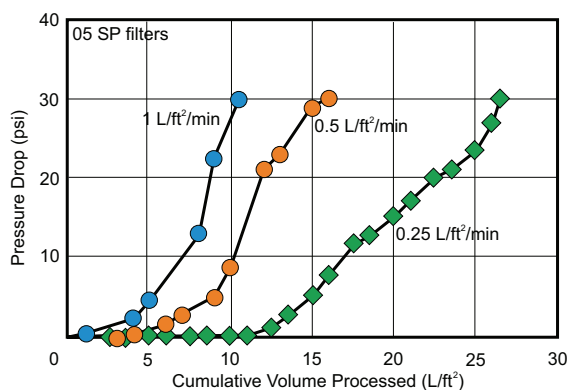

**Figure 3 — Filter Throughput vs. Flux Rate**

Figure 2 shows throughput results with fresh cells and cells frozen and thawed once or twice. With increasing freeze/thaw cycles, cell viability decreases as cellular debris is generated, making filtration more difficult. Figure 3 shows the effect of flux (flow per unit area) on throughput. As flux increases, throughput decreases. The optimum flux for mammalian cell culture clarification using Zeta Plus filters is 0.25-0.5 L/min/ft<sup>2</sup>. Larger scale (> 1000 L) cell culture systems typically require two stages of Zeta Plus depth filtration prior to 0.2 micron filtration. Standard grade or extended throughput Zeta Plus EXT grade are recommended for each stage and typical grades and throughput volumes are summarized in Table 3.

**Table 3 — Recommended Grades of Zeta Plus for Cell Separation**

| Cell Separation Stage | Zeta Plus Grade and Type          | Recommended Flux   | Typical Throughput   |
|-----------------------|-----------------------------------|--|--|
| 1                     | 05SP, 10SP, 30LA,<br>10M02, 30M02 | 0.25-0.5 LPM/ft <sup>2</sup><br>0.25-0.5 LPM/ft <sup>2</sup> | 10-20 Liters per ft <sup>2</sup><br>15-40 Liters per ft <sup>2</sup> |
| 2                     | 60SP, 60LA,<br>60M03              | 0.25-0.5 LPM/ft <sup>2</sup><br>0.25-0.5 LPM/ft <sup>2</sup> | 15-30 Liters per ft <sup>2</sup><br>25-60 Liters per ft <sup>2</sup> |

Each of the Zeta Plus filters referenced in Table 3 can be steam sterilized and is designed for single use. Because Zeta Plus filters are used once and disposed following use, opportunity for cross batch contamination is eliminated and clean-in-place (CIP) validation is substantially reduced.

### 3. Clarification of Protein Concentrate

Following cell separation, the clarified culture suspension is filtered through a 0.2 micron rated membrane filter and stored for downstream purification. The first downstream purification step typically involves concentration and diafiltration using an ultrafiltration membrane. The purpose of concentration is to reduce the fluid volume for easier handling and chromatographic steps. Diafiltration involves solvent exchange with the objective of completely removing cell growth media constituents and replacing them with a physiological buffer system more suited for chromatography. One of the consequences of concentration is that protein solutions often become turbid due to precipitation of denatured protein and other constituents. One or two stages of filtration may be required to clarify concentrated protein solutions and to remove particulates that can plug expensive downstream chromatography columns. Table 4 summarizes the filtration steps recommended for this application.

**Table 4 — Clarification of Concentrated Protein Solutions**

| Filter Stage | Filter Type                           | Typical Throughput Volume |
|--------------|---------------------------------------|---------------------------|
| 1            | Zeta Plus 60ZA or Zeta Plus EXT 60M02 | 5- 15 L/ft <sup>2</sup>   |
| 2            | LifeASSURE PLA020, 0.2 micron         | 5- 15 L/ft <sup>2</sup>   |

### 4. Chromatography Column Protection

Chromatography is the most commonly used unit operation in downstream purification and most purification schemes utilize three or more chromatographic steps. In all cases, chromatography media is expensive and consistent performance is dependent on maintaining free flow through the column. Failure to remove contaminants and debris prior to loading chromatography columns can cause column plugging and channeling. 0.2 micron rated membrane filters are recommended for filtration of product loaded onto columns and for filtration of elution buffers and regeneration chemicals. Product solution and most buffers are aqueous and do not typically cause compatibility problems with 0.2 micron rated membrane filters. Regeneration chemicals, however, are typically alkaline pH caustic fluids that can cause compatibility problems. CUNO LifeASSURE 0.2 micron rated filters are compatible with caustic regeneration chemicals and thus can be used to directly filter caustic applied to columns. In order to assess compatibility, LifeASSURE filters were exposed to 0.6 M NaOH at 60C for up to 50 hours. Each of the filters tested was determined to have maintained compatibility based on forward flow integrity test results.

## 5. Final Fill Prefiltration

Following purification of the desired monoclonal antibody, the final processing steps involve aseptic filling of vials or lyophilization. Aseptic filling requires final filtration using 0.2 micron rated sterilizing grade filters, or in some instances, 0.1 micron rated final filters. In order to ensure trouble-free sterilizing filter performance, a 0.2 micron rated prefilter is often used. LifeASSURE PLA020 filters are recommended for this application. The multi-zone Flex-N LifeASSURE membrane construction provides high flow rates, high bioburden reduction (LRV typically 7.3) and high contaminant capacity. These attributes ensure excellent protection of downstream sterilizing filters and economical system sizing.

## Conclusion and Summary

This CUNO Application Brief has focused on filtration processes applied in purification of monoclonal antibodies. These processes include: filtration of growth media fermenter feeds, cell separation following fermentation, clarification of protein concentrates, prefiltration prior to column chromatography and prefiltration prior to sterilizing filtration. The problems associated with each filtration stage and the solution to these problems is presented. The recommendations for filtration at each stage are summarized in Table 5 and provide process engineers with a framework for filter selection.

**Table 5 — Filter Recommendations**

| <b>Monoclonal Antibody Purification Step</b> | <b>Recommended Filter</b>   |
|--|---|
| Growth Media                                 | Zeta Plus VR for Viral Reduction, LifeASSURE PB 0.2 micron, Zetapor 020SP 0.2 micron  |
| Cell Separation                              | <b>Stage 1</b> — Zeta Plus 05SP, 10SP, or 30LA , or Zeta Plus EXT 10M02 or 30M02<br><b>Stage 2</b> — Zeta Plus 60SP or 60LA Zeta Plus EXT 60M02 |
| Clarification of Protein Concentrate         | <b>Stage 1</b> — Zeta Plus 60ZA or Zeta Plus EXT 60M02<br><b>Stage 2</b> — LifeASSURE PB 0.2 micron   |
| Chromatography Column Protection             | LifeASSURE PB 0.2 micron  |
| Final Fill Pre-filtration                    | LifeASSURE PB 0.2 micron  |

## Additional CUNO Literature

| Title   | Literature Identification |
|---|---------------------------|
| CUNO Filter Systems for Bioprocess and Biological Separations   | LITCATBP                  |
| Zeta Plus VR Series Filter Cartridges   | LITZPVR                   |
| Zeta Plus EXT Series Filter Cartridges  | LITZPMAX1                 |
| LifeASSURE™ PB Capsule and Cartridge Filters  | LITCLAPB1                 |
| Zetapor™ 020SP Membrane Filters   | LITZRSP3                  |
| ZPC/ZPB Model Zeta Plus Filter Housings   | LITHS.ZPBC                |
| ZWC/ZWB Model Zetapor Filter Housings   | LITHSZWBC                 |
| CUNO Application Brief — Chromatography Column Protection with CUNO LifeASSURE PB Membrane Filters              | LITCABLA2                 |
| CUNO Application Brief — Filtration of Cell Culture Growth Media and Process Buffers                            | LITCABLA3                 |
| CUNO Application Brief — Zeta Plus Depth Filtration and Alternative Technologies for Cell Culture Clarification | LITCABZPS1                |

## CUNO Literature Descriptions

**CUNO Filter Systems for Bioprocess and Biological Separations** — CUNO is a leader in advanced depth filter systems and membrane-based separations, offering a range of products for all stages of biopharmaceutical and biological processing from bench top to pilot-scale to manufacturing scale operations.

**Zeta Plus™ VR Series Filter Media** — The removal and/or inactivation of contaminating viruses from biotherapeutics is a requisite for ensuring final product safety. Zeta Plus VR Series cartridge depth filters remove significant levels of viruses from biological fluids. They provide validatable viral titer reduction, high flow rates, scalability, economy, disposability and ease-of-use in the biological manufacturing environment. The Zeta Plus VR Series includes specific filter media recommendations for virus removal from blood plasma proteins and bioprocess-derived cell culture fluids.

**Zeta Plus EXT Series Filter Media** — Now added to this well-established family of Zeta Plus filters is the ground-breaking Zeta Plus EXT Series. Featuring a new dual zone construction, Zeta Plus EXT Series filters significantly increase throughput per unit area of filter media, while optimizing the desired effluent clarity. Zeta Plus EXT filter media consists of two distinct layers, or “zones” of filter media with the upstream zone more open than the downstream zone. This structure enhances the contaminant holding capacity of the filter media, since larger particles are trapped in the upper zone of the filter media and smaller particles are trapped in the lower zone, reducing premature plugging and extending service life. These two layers can be selected independently of each other to optimize performance. Standard combinations determined to have the optimum through-puts are included in the ordering guide on the back, although the user can select custom arrangements if required.

**LifeASSURE™ PB Cartridge and Capsule Filters** — LifeASSURE PB filter cartridges and capsules are our latest advance in membrane filter technology. Encompassing two leading-edge processes, FlexN membrane manufacture and MaxMedia pleating construction, the LifeASSURE PB series of filters offers unmatched protection of final membrane filters, as well as exceptionally long service life. Designed with pleated Nylon 6,6 membrane in an all-polypropylene cartridge construction, LifeASSURE PB filters are ideally suited for a wide range of prefiltration and clarification applications in the pharmaceutical, biological, and bioprocess industries.

**Zetapor™ SP Sterilizing Grade Cartridge and Capsule Membrane Filters** — CUNO pioneered the development of charge modified Nylon 6,6 filters for the pharmaceutical industry. Zetapor sterilizing grade filters and capsules are validated for absolute bacteria retention and provide reliable sterile filtration performance. In addition to a fixed bacteria retentive pore structure, Zetapor membrane is charge modified to provide enhanced removal of negatively charged biological contaminants such as endotoxin, virus and nucleic acid fragments. The combination of a validated bacteria retentive membrane, together with enhanced removal of negatively charged contaminants, make Zetapor membrane an ideal choice for pharmaceutical and biopharmaceutical sterilizing applications.

**Zeta Plus ZPC & ZPB sanitary filter housings** provide the ultimate standard for totally enclosed Zeta Plus filter cartridge systems. Constructed from 400 grit, mirror finish, 316L stainless steel, Zeta Plus ZPC & ZPB housings meet the exacting sanitary quality standards of the pharmaceutical, food and beverage, fine chemical, and microelectronics industries. Both housing styles accommodate from one to four 8”, 12”, or 16” diameter Zeta Plus filter cartridges to offer a wide choice of filter media area and flow rates.

**Zetapor ZWC & ZWB sanitary design cartridge housings** provide the ultimate for critical clarification and sterile filtration applications. Manufactured to the strictest of standards and from high quality 316L stainless steel, the ZWC & ZWB mirror polished filter housings are designed to meet the exacting quality standards of the food & beverage industry. The ZWC & ZWB series are multi-cartridge housings designed to accommodate four, eight, eleven, or twenty-one sanitary style filter cartridges up to 40 inches long.

## Scientific Applications Support Services

The cornerstone of our philosophy is service to customers, not only in product quality and prompt service, but also in problem solving, application support and in the sharing of scientific information. Our **Scientific Applications Support Services (SASS)** group is a market-oriented group of scientists and engineers who work closely with customers to solve difficult separation problems and aid in the selection of the most effective and economical filtration systems. CUNO offers specialized support to the pharmaceutical and biotechnology industry through our **Validation Support Services Program**.

SASS routinely provides end-users with:

- Validation And Regulatory Support
- Extractable And Compatibility Analysis
- Filter System Optimization Studies
- CUNOCheck 2 Integrity Tester Validation.

For more information regarding Validation Support Services, please contact CUNO Technical Services or your local CUNO Distributor.

